

# UNTHA

The reliable brand!



## LRK CLASS

1-shaft shredder for high performance requirements in material recycling



## Powerful and **efficient**

The reliable and rugged LRK class shredders are popular with companies in the plastics processing industry for volume reduction and in-house recycling.

Like all UNTHA shredders, these machines can stand alone or be integrated into comprehensive systems. High throughput, outstanding availability and consistent particle sizing ensure an efficient and profitable operation.

### Areas of application

- » Plastic film
- » Plastic lumps
- » Rubber waste
- » Cardboard packaging
- » Cardboard cores
- » Plastic & paper packaging material
- » Plastic drums
- » Plastic pipes
- » Foam boards
- » Plastic bottles
- » Plastic pallets
- » Production waste
- » Punching scrap (skeletal waste, non-metal)
- » Automotive car bumpers
- » Tetra pack
- » Automotive interior panels
- » etc.



## UNTHA Research & Development Centre

In 2000, UNTHA opened a modern research and development centre where trials and tests with customers' specific materials are simulated under practical conditions.

The focus is always on the customer and on fulfilling each task in the best possible manner. The technology centre enables us to gain important experience and data so we can offer the ideal shredding solution for any given task.

Take this opportunity and make an appointment at our test and demonstration centre!

# Your benefits at a glance

---

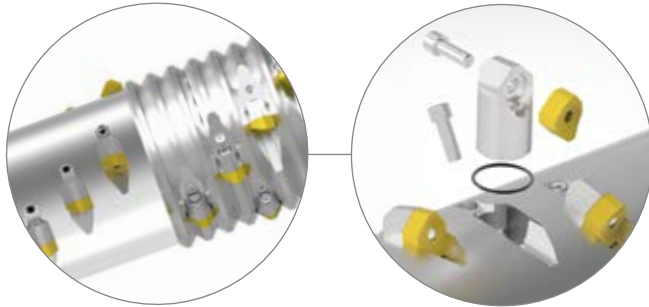

## Effective cutting system

The special rotors (smooth or profiled) are equipped with bolted cutter holders. The adjustable main and secondary cutting bar as well as the cutters may be reversed up to 4 times.

## Robust machine body

The compact construction facilitates a space-saving set-up and smooth integration in the overall plant. A low filling level ensures maximum flexibility when it comes to loading. The large filling volume increases the process safety and reduces the risk of bridge formations.



## Exchangeable perforated screens

Depending on the granule size, perforated screens are available in a range of diameters. Replacing or cleaning the screens is easy and time efficient.





### Low-maintenance pusher system

The powerful feeder and the cutting system ensure high throughput rates. The low-wear feeder guide provides for a long service life and low maintenance costs.



### Highly user- and maintenance-friendly

The easy-to-use control unit comes with three different programme settings, facilitating the efficient processing of different materials.

The service flap provides speedy access to the cutting chamber of the shredder, facilitating safe and efficient maintenance for maximum uptime.

### High-performance power train

The high-performance power train ensures a high rotor torque, and an integrated shock absorber protects the drive system and provides for quiet running levels.



Symbolic image LRK1000.



## Options

### Special Equipment

- » **Automatic central lubrication system:** All important lubrication points are supplied continuously with lubricant and hence are less prone to wear.
- » **45° machine frame:** Provides a larger feed opening and increased hopper volume.
- » **Hold-down device:** Ensures the efficient shredding of bulky and light materials.
- » **Rotor wear protection (hard surfacing):** Significantly increases rotor availability with abrasive materials.

### Accessory

- » **Special attachment hoppers:** For optimal adjustment to the input material and feeding method.
- » **Rotor cooler:** Ensures the reliable shredding of materials with a particularly low melting point.
- » **Discharge screw:** For easy and efficient discharge.
- » **Flexible controller upgrades:** Facilitates customer-specific control system adaptations and enhancements.

### Services

- » **UNTHA Carefree Packages (Basic, Standard, Professional):** Ensure that machines are technically sound and ready for use at all times.
- » **UNTHA Lifetime Support:** Guarantees maximum availability throughout the lifetime of the machine.

# LRK

1-shaft shredding system

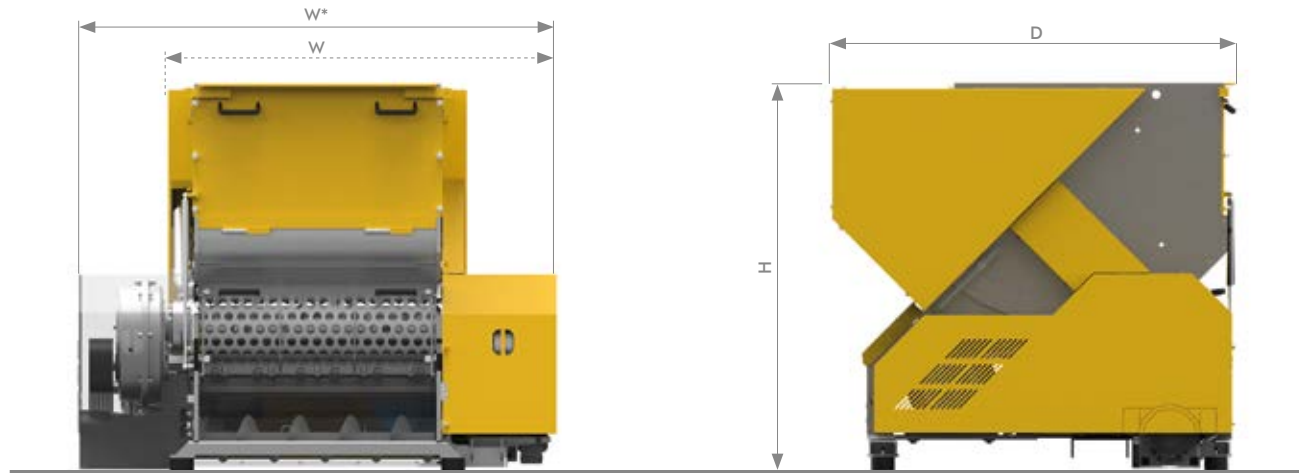

SPECIFICATIONS		LRK700	LRK1000	LRK1400
Drive power	kW	18.5	22/30/2 x 22	30/44/2 x 30
Hydraulic power	kW	1.1	1.1/1.5	1.5
Ø Rotor	mm	300	300	300
Rotor speed	rpm	98	98	98
Number of cutters	pcs.	19 - 38	27 - 81	38 - 114
Feed opening	mm	700 x 1,050	1,000 x 1,050	1,400 x 1,050
Required suction speed	m/s	28	28	28
Weight	kg	1,800	3,000 - 3,400	3,500 - 3,800
Ø Screen	mm	15 - 40	15 - 40	15 - 40

	LRK700	LRK1000	LRK1400
W (mm)	1,519	1,863/2,010*	2,209/2,406*
D (mm)	1,712	1,705	1,705
H (mm)	1,630	1,630	1,645

Dimensions in mm  
\*) Two-sided drive

## UNTHA shredding technology GmbH

Kellau 141  
5431 Kuchl | Österreich  
Tel.: +43 6244 7016 0  
Fax: +43 6244 7016 1  
info@untha.com  
www.untha.com

## UNTHA Deutschland GmbH

Am Hammersteig 5a  
97753 Karlstadt | Deutschland  
Tel.: +49 9353 906869-0  
Fax: +49 9353 906869-35  
info@untha.de  
www.untha.de

## UNTHA UK Ltd.

Excel House, Becklands Close  
Boroughbridge  
YO51 9NR | United Kingdom  
Tel.: +44 845 4505 388  
sales@untha.co.uk  
www.untha.co.uk

## UNTHA America, Inc.

1 Lafayette Road, Building 4  
Hampton, NH 03842 | USA  
Tel.: +1 603 601 2304  
Fax: +1 603 601 7573  
info@untha-america.com  
www.untha-america.com

## UNTHA Polska Sp. z o.o.

Olecka 23/221  
04-980 Warszawa | Polska  
Tel.: +48 12 6421896  
Fax: +48 12 6421896  
info@untha.pl  
www.untha.pl

## UNTHA Ibérica S.A.

Polígono de Sigüeiro - Parcela 58, Sigüeiro - Oroso / A  
Coruña | España  
Tel.: +34 981 69 10 54  
Fax: +34 981 69 08 78  
info@untha-iberica.com  
www.untha.es

## 5 reasons to choose UNTHA



Customised, long-lasting shredding solutions



Premium quality products and services



All-encompassing expertise, from development to production, under one roof



Reliable customer service with the best technical know-how



More than 10,000 satisfied reference customers worldwide

## We deliver what we promise

Since our founding in 1970, we've followed our promise of being "the reliable brand", which applies to every product and service that UNTHA delivers.

We work hard to consistently outperform our competitors, and provide customers with the confidence that – in choosing UNTHA – they have made the best decision for their business.

All revisions reserved. Subject to setting and printing errors.  
All illustrations are representative and may deviate from the actual product.  
© 07/20 UNTHA shredding technology